



Инструкция к заказу

Bild A/Fig. A:

Kohlebürstenabmessungen/ Dimensions

Die Maße einer Kohlebürste werden nach DIN IEC 136 Teil 3 und nach DIN 43 000 Blatt 1, in der Reihenfolge $t \times a \times r$ angegeben.

Carbon-brush dimensions are given in accordance with DIN IEC 136, Part 3, and DIN 43 000, Sheet 1, in the following sequence: $t \times a \times r$.

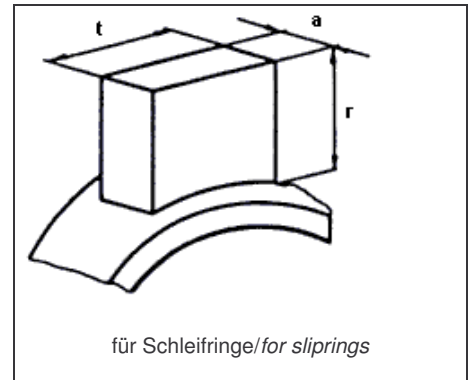
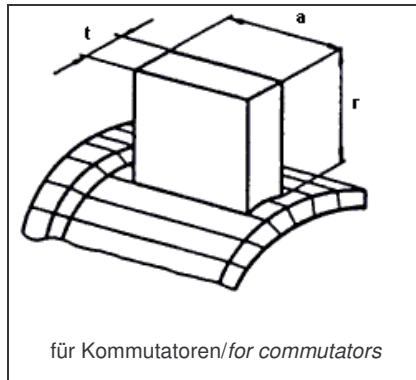

Maßbuchstabe	Maßbenennung
<i>Dimensional letter</i> (IEC 163 und DIN 43 000)	<i>Explanation of the dimensions</i>
t	Breite der Kohlebürste in Richtung des Umfangs (tangential). <i>Width of the carbon brush in the direction of the circumference (tangential).</i>
a	Länge der Kohlebürste in Richtung der Achse (axial). <i>Length of the carbon brush in direction to the axis (axial).</i>
r	Länge der Kohlebürste in Richtung des Halbmessers (radial). <i>Length of the carbon brush in direction to the radius (radial).</i>

Bild B/Fig. B: Kabelauführung/Cable dimension

Anzugeben ist die sichtbare Kabellänge zwischen Kohle und Schuh.
Please indicate the visible length between the carbon brush and the cable lug.

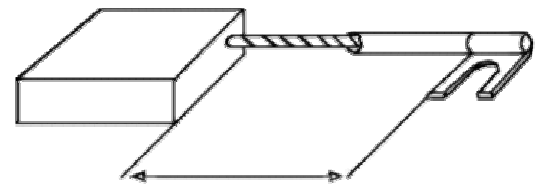

Kabellänge in mm
Cable length in mm

**Bild C/Fic. C:
Kabeleinführung
Configuration of
cable insertion**

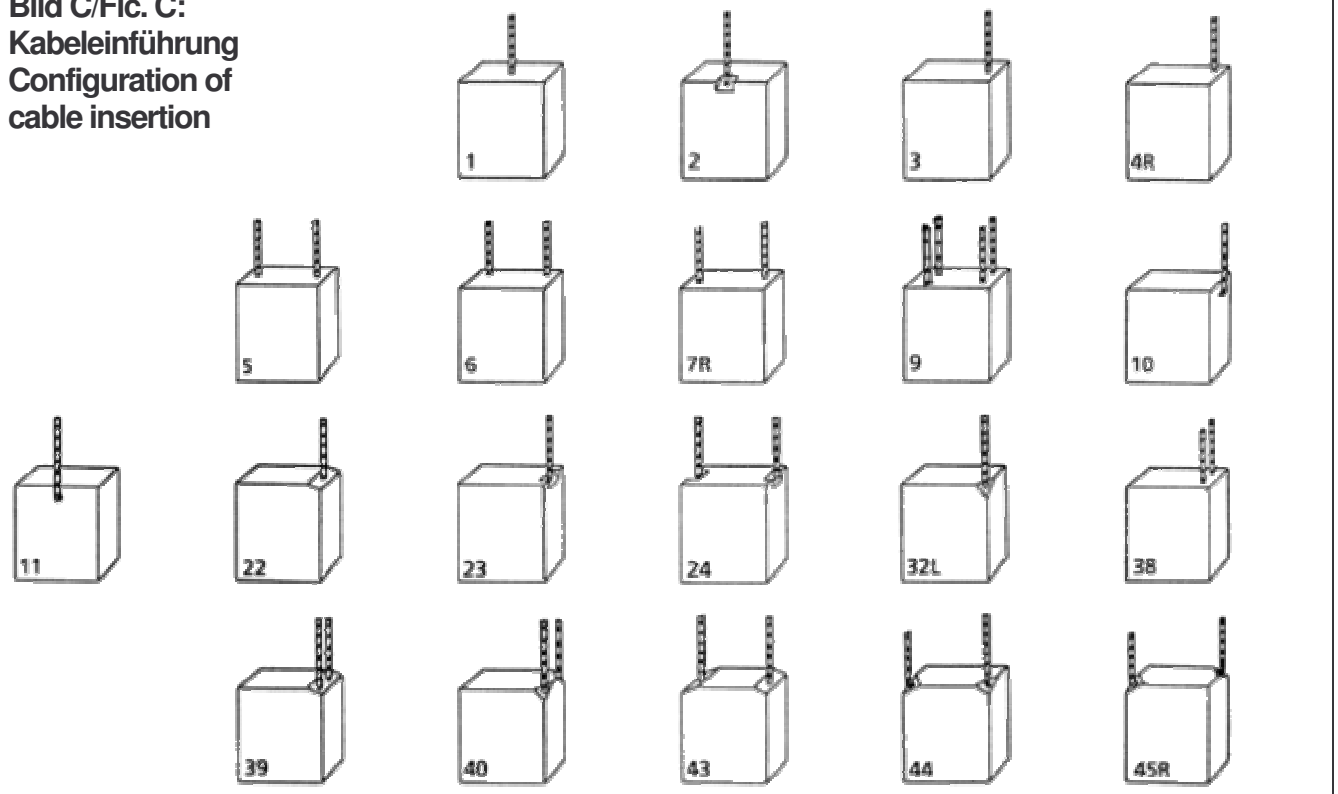

Инструкция к заказу

Bild D/Fig. D: Kabelschuhe/ Cable lugs

Loch- bzw. Schlitzbreite
für M3 bis M10

Hole and slot width
for M3 to M10



Bild E/Fig. E: Armaturen/ Shunt attachments



gl-glatt
sm-smooth

NB-Nietbügel
r-rivet clamp

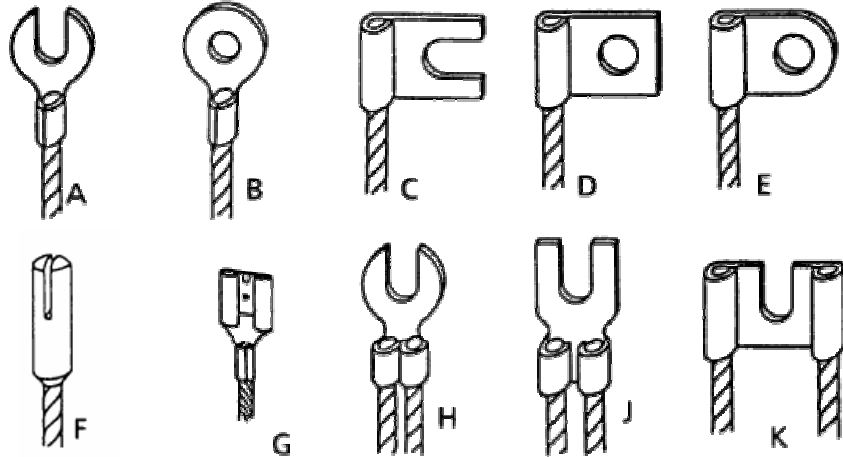
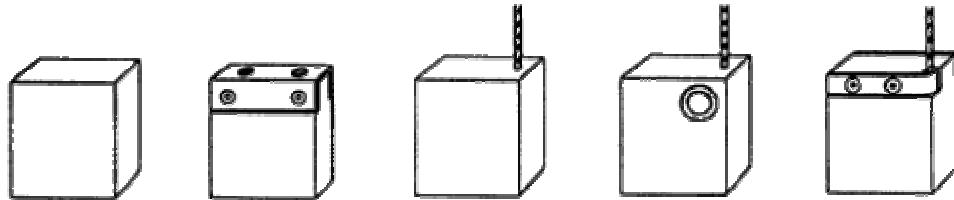
st-Stampfkontakt
tc-tamped contact

N-Nietkontakt
rc-rivet contact

NL-Nietlasche
rs-rivet straps

Bild F/Fig. F: Ausführungen/Special design features

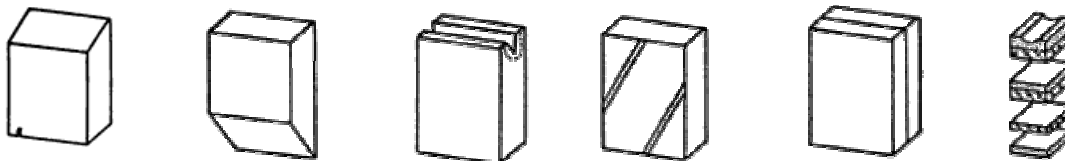

Kopfschräge
top bevel

Laufschräge
bottom bevel

Kopfkerbe/-rinne
top groove

Staubrillen
dust slot

Zwilling
duplex wafer

Druckfinger- und
Dämpfungs-platte/
fibre material/rubber top